

WIPAC

ALTERNATOR EQUIPMENT

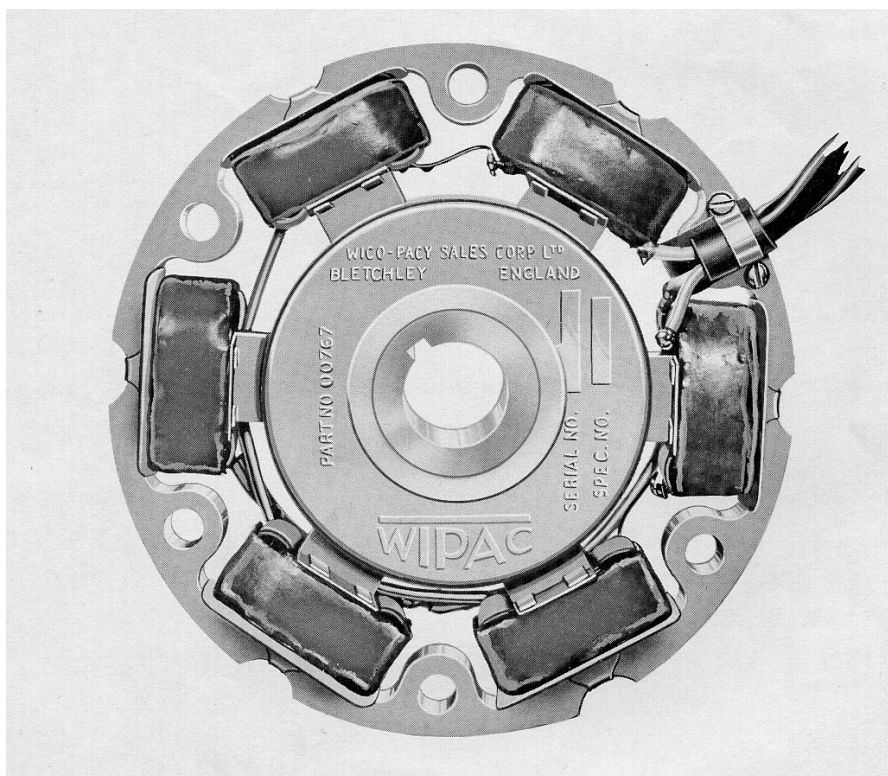

Specifications for D.O.T. 350cc Twin Two Stroke, March '59

Alternator Unit	G1557
Rectifier	S2642
Rectifier Lead	S0778
Set	
Distributor Unit	S1021
Ignition Coil	S0769
H.T. Lead Unit	S0773

Service Instructions

Removal of Alternator

When the stator ring with its coils is removed for inspection or replacement, the visible solder connections should be checked to make sure none are touching each other, nor touching "earth". Before replacement, ensure that the pole surfaces are free from metallic dust and that the main cable is clear from any moving parts. See also note on "magnetic rotor".

Magnetic Rotor Unit

This is a 6-pole unit and can be removed or stored indefinitely without loss of magnetism. When being replaced, care should be taken to make sure that the shaft key-way position is correct as there are variations.

Check the outside diameter, because these also vary, and they must be used with their corresponding stator ring to maintain the common air-gap of approximately 0.007".

Distributor Unit

This comprises the contact set, condenser and cam. The contact set is designed to be replaced as a complete unit and not intended to have the replacement of either fixed or moving contact separately. The only attention needed to the condenser is a periodic check of the tightness of both its electrical connections - live and earth.

Oil should not be applied to the cam lubricating pad. The pad should be removed and a quantity of high melting point grease worked into it.

Breaker Point Setting

The contact gap should be maintained at the figure specified in the vehicle manufacturer's instruction book. This is particularly important on Sports machines using A.C. feed for ignition. A difference of as little as 0.002" can have an appreciable effect on performance.

Alternator Unit: G1557

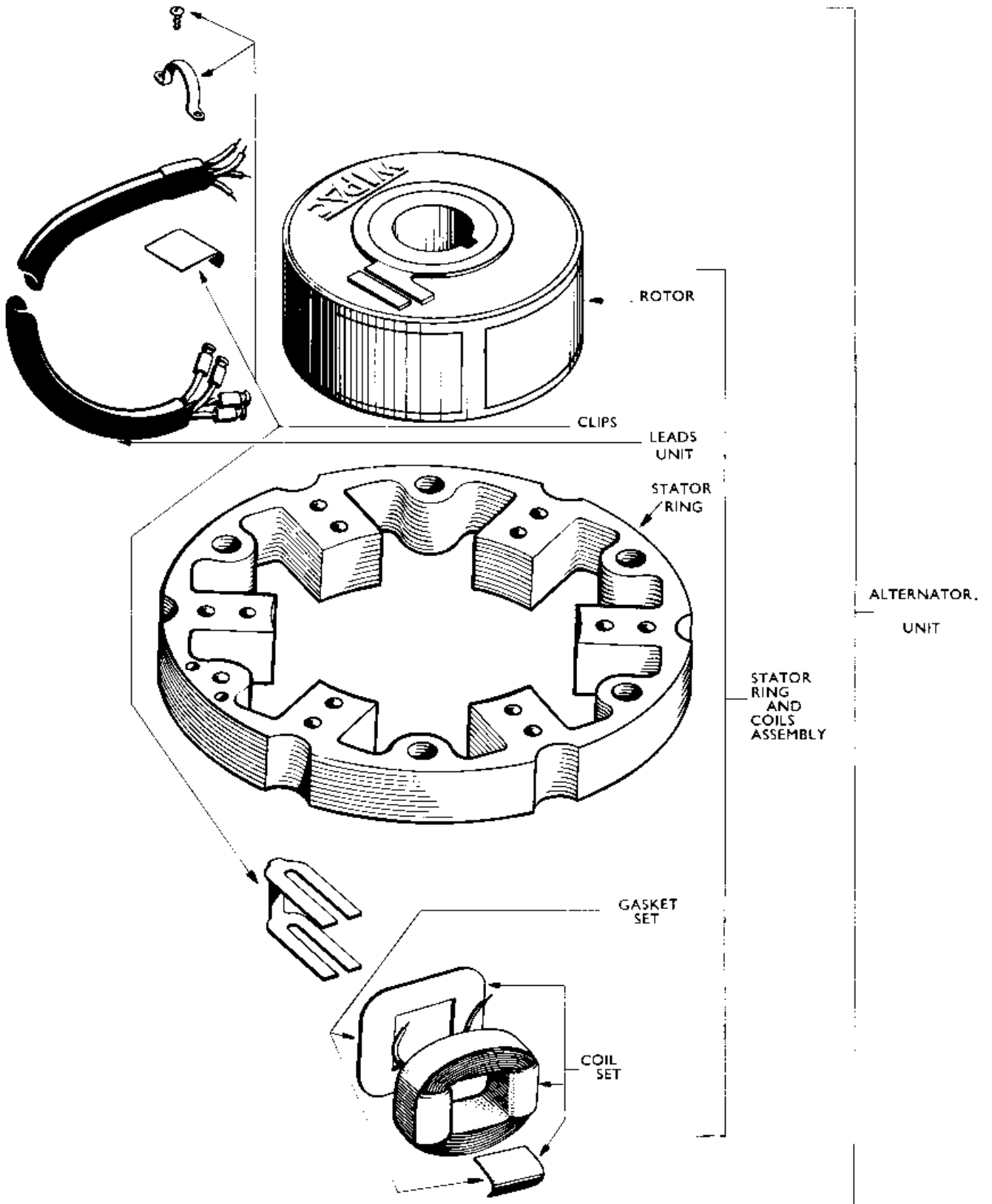

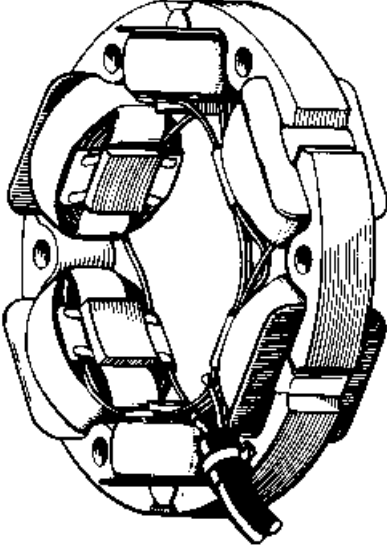
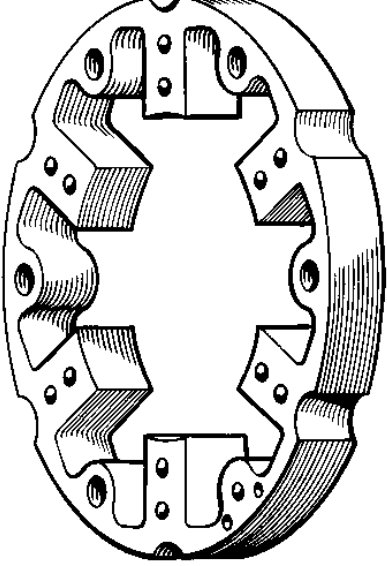
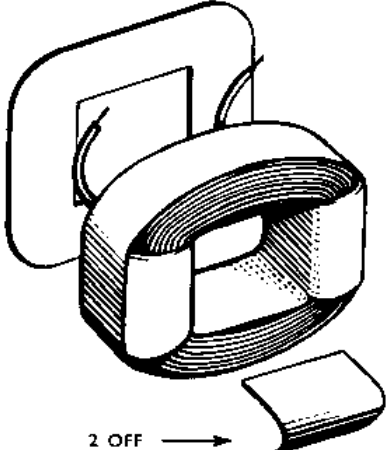

GENERAL ILLUSTRATION

DOT MOTORCYCLE CLUB 2010

Component	Illustration	Part No.	Comment
<p>Stator Ring & Coils Assembly</p>		<p>S0602</p>	<p>6 coils.</p>
<p>Stator Ring</p>		<p>S0218</p>	<p>also fitted to all models Norton Jubilee & Navigator.</p>
<p>Coil Set (grouped)</p>	<p>Set of 6x S0483</p>	<p>S0219</p>	<p>includes Gasket Set S2598 also fitted to all models Norton Jubilee & Navigator.</p>
<p>Coil Set (single)</p>	 <p>2 OFF →</p>	<p>S0483</p>	<p>also fitted to all models Norton Jubilee & Navigator.</p>

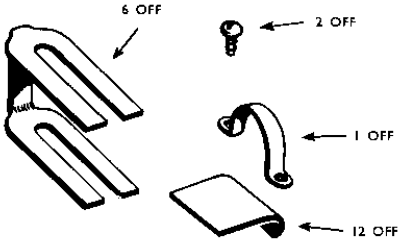
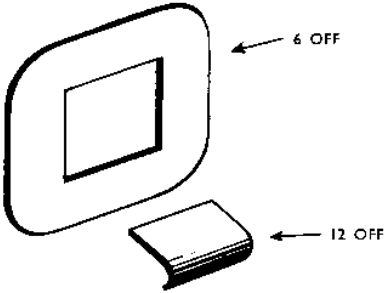
DOT MOTORCYCLE CLUB 2010

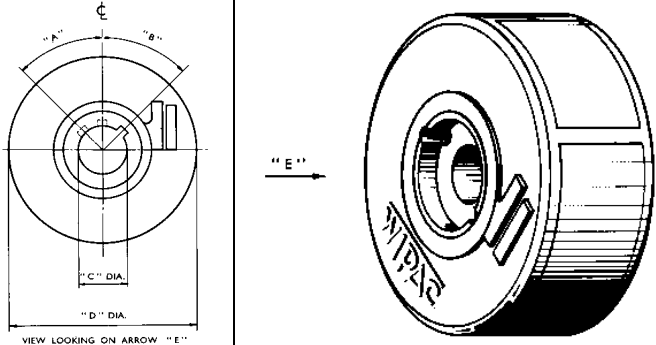
Component	Illustration	Part No.	Comment
Clips and Screws		S2385	<p>for Coil Attachments & Leads.</p> <p>also fitted to all models Norton Jubilee & Navigator.</p>
Gasket Set		S2598	<p>also fitted to all models Norton Jubilee & Navigator.</p>
Leads Unit		S0603	<p>includes Clips and Screws S2385.</p>
Rotor		S0788	<p><u>Keyway Position 'B'</u> 22°</p> <p><u>'C' Diameter</u> 0.711" to 0.709" max. Taper 10° Inclusive</p> <p><u>'D' Diameter</u> 2.900" to 2.902"</p>

Rectifier

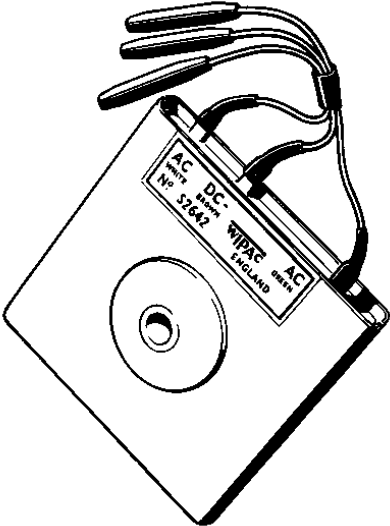
Component	Illustration	Part No.	Comment
Rectifier		S2642	as fitted to all models Norton Jubilee & Navigator.

Rectifier Lead Set

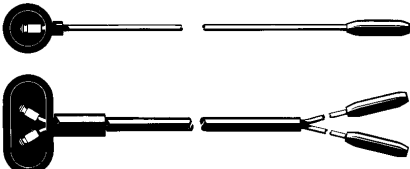
Component	Illustration	Part No.	Comment
Rectifier Lead Set		S0778	-

Distributor Unit: S1021

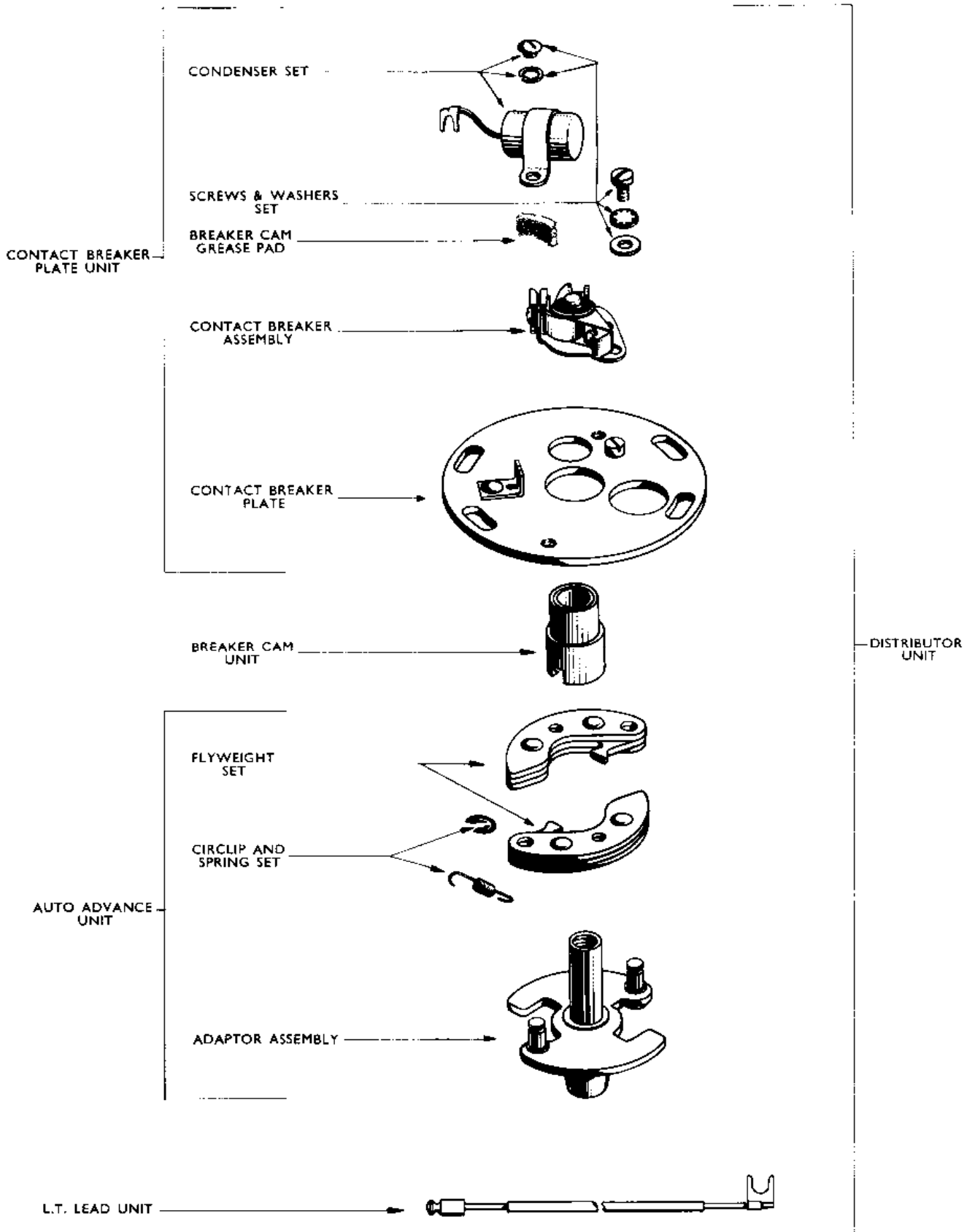



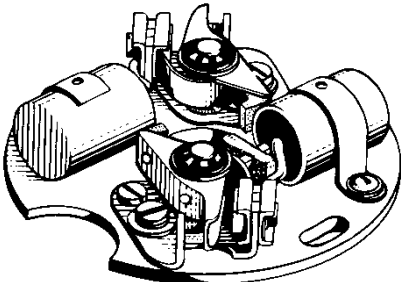
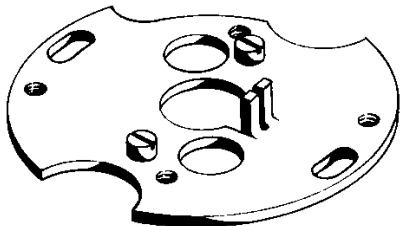
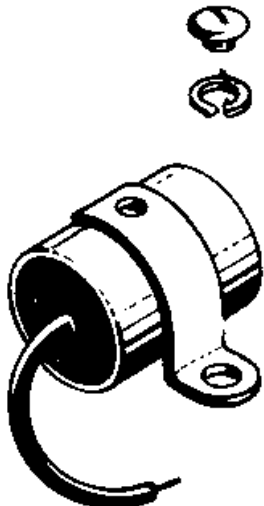
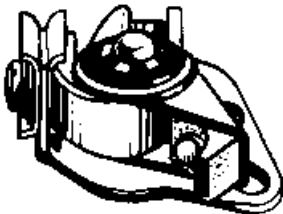
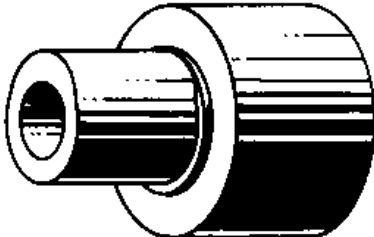

GENERAL ILLUSTRATION

DOT MOTORCYCLE CLUB 2010

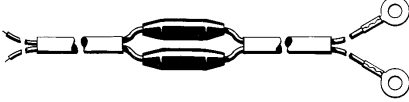
Component	Illustration	Part No.	Comment
Contact Breaker Plate Unit		S0759	also fitted to Norton Jubilee & Navigator, to August '60.
Contact Breaker Plate Only		S0760	also fitted to Norton Jubilee & Navigator, to August '60.
Condenser Set		S0761	2 sets required. also fitted to Norton Jubilee and Navigator, to August '60.
Contact Breaker Assembly		S0584	2 sets required. also fitted to all models Norton Jubilee & Navigator.
Cam Unit		S0790	-

DOT MOTORCYCLE CLUB 2010

Component	Illustration	Part No.	Comment
L.T. Lead Unit		S0789	-
Screws and Washers Set	<p data-bbox="520 499 584 521">2 OFF</p>  <p data-bbox="520 562 584 584">EACH</p> 	S0767	also fitted to all models Norton Jubilee & Navigator.
Cam Grease Pad		S1994	also fitted to all models Norton Jubilee & Navigator.

Possible Alternative Components

(as fitted to Norton Jubilee & Navigator, September '60 onwards)

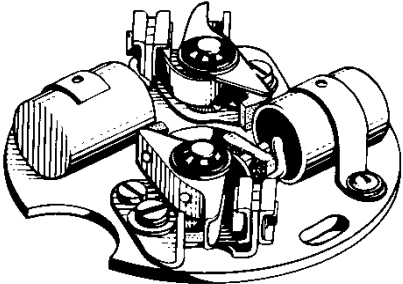
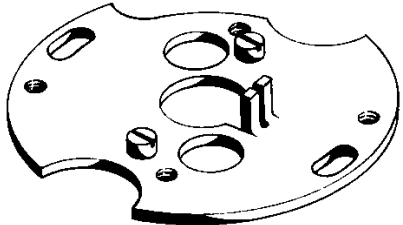
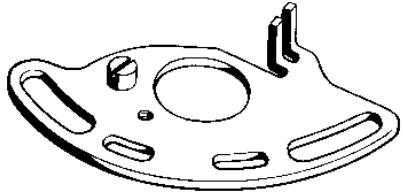
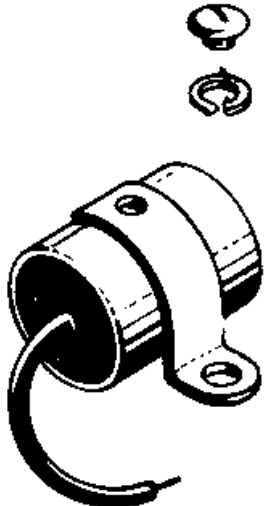
Component	Illustration	Part No.	Comment
Contact Breaker Plate Unit		S2631	-
Contact Breaker Plate Only		S2634	-
Contact Breaker Plate (Adjustable)		S2635	-
Condenser Set		S2767	2 sets required.

Ignition Coil: S0769

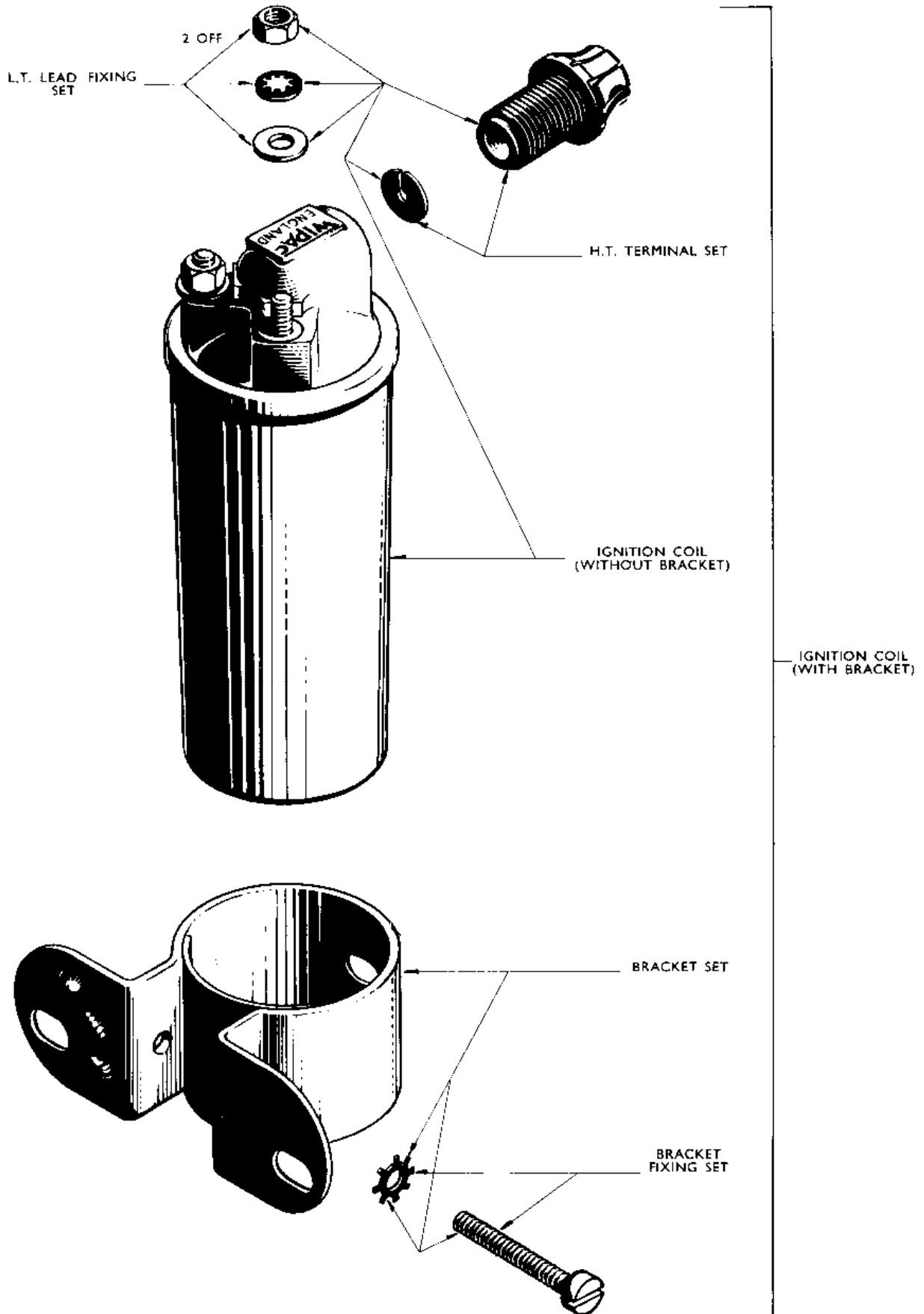

GENERAL ILLUSTRATION

DOT MOTORCYCLE CLUB 2010

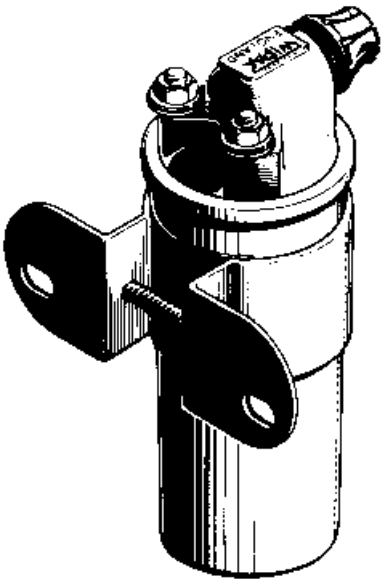
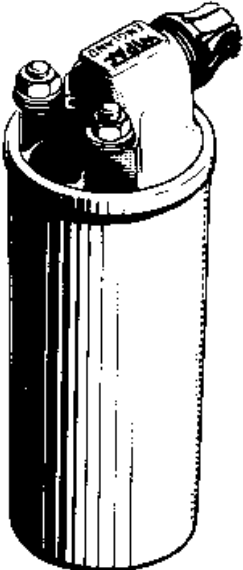
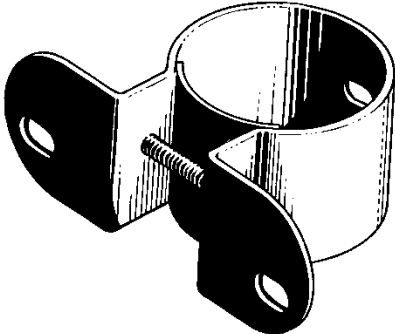
Component	Illustration	Part No.	Comment
Ignition Coil with Bracket		<p>S0769</p> <p>S0793</p> <p>S0810</p>	<p>6V, suitable for 5mm diameter H.T. lead.</p> <p>6V, suitable for 7mm diameter H.T. lead (alternative component, as fitted to all models Norton Jubilee & Navigator).</p> <p>12V, suitable for 7mm diameter H.T. lead (possible alternative component, as fitted to lightweight AMC Scrambles models).</p>
Ignition Coil without Bracket		<p>S0770</p> <p>S0794</p> <p>S0811</p>	<p>6V, suitable for 5mm diameter H.T. lead.</p> <p>6V, suitable for 7mm diameter H.T. lead (alternative component, as fitted to all models Norton Jubilee & Navigator).</p> <p>12V, suitable for 7mm diameter H.T. lead (possible alternative component, as fitted to lightweight AMC Scrambles models).</p>
Bracket Set		<p>S0771</p>	<p>-</p>

DOT MOTORCYCLE CLUB 2010

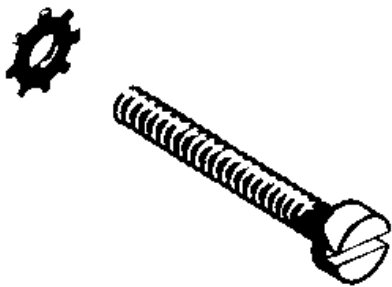
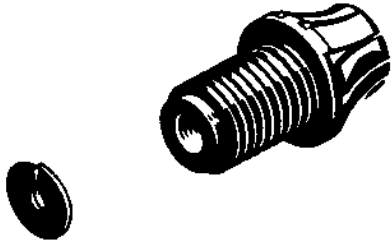
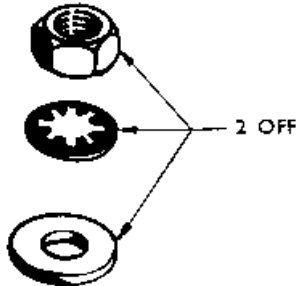
Component	Illustration	Part No.	Comment
Bracket Fixing Set		S1106	-
H.T. Terminal Set		S0772 S0795	suitable for 5mm diameter H.T. lead. suitable for 7mm diameter H.T. lead (alternative component, as fitted to all models Norton Jubilee & Navigator).
L.T. Lead Fixing Set		S0813	-

H.T. Lead Unit

Component	Illustration	Part No.	Comment
H.T. Lead Unit		S0773	5mm diameter lead.